

QUAKER QUINTOLUBRIC 882

FIRE-RESISTANT HYDRAULIC FLUIDS BETTER THREE WAYS

1. SAFE

QUINTOLUBRIC 822 fluids are fire-resistant. Approved by Factory Mutual Research and the Bureau of Mines(M.S.H.A). QUINTOLUBRIC 822 can be handled without operator discomfort, and when burned, generates non-toxic, non-noxious smoke.

PRODUCT SAFETY INFORMATION

The acute oral toxicity and primary skin and eye irritative potentials of QUINTOLUBRIC 822 were evaluated in accordance with the techniques specified in the Regulations for the Enforcement of the Federal Hazardous Substances Act (Code of Federal Regulations, Title 16, Chapter 11,1976). Based on this evaluation, QUINTOLUBRIC 822 is classified as non-toxic by oral ingestion; is not a primary skin irritant or corrosive material; and is not an eye irritant as defined in the above cited Regulations.

Specific data are:

Acute Oral Toxicity, LD ₅₀	>10 ml./kg.
Primary Irritant Index (Dralze Scale)	1.46
Contact Hypersensitivity	

ENVIRONMENTAL CONSIDERATIONS

QUINTOLUBRIC 822 fluids have a specific gravity less than that of wafer; so they can be removed from ponds and collection tanks by standard skimming techniques. QUINTOLUBRIC 822 fluids do not contain phenols, nor phenol derivatives. Therefore, in water, QUINTOLUBRIC 822 cannot revert to phenol type compounds. QUINTOLUBRIC 822 does not contain any materials considered hazardous under EPA criteria or the Hazardous Substances Act.

Like other synthetic fluids, QUINTOLUBRIC 822, under the proper circumstances, will burn. Unlike phosphate esters, QUINTOLUBRIC 822 when burning, does not evolve large volumes of dense and noxious smoke. A phosphate ester burning, because of its objectionable smoke, often interferes with the timely control of the fire. Products of combustion from a QUINTOLUBRIC 822 fire may be likened to those found in a mineral oil fire.

2. SIMPLE

QUINTOLUBRIC 822 fluids feature a high degree of fire resistance and lubricity and are 100% synthetic. Specifically formulated to replace phosphate ester fluids in fire-hazard hydraulic applications without introducing major operating problems. QUINTOLUBRIC 822 is available in three viscosities: 220 S.U.S. @ 100°F; 300 S.U.S. @ 100°F; 450 S.U.S. @ 100°F to meet all your hydraulic application requirements.

TYPICAL PROPERTIES QUINTOLUBRIC 822

	822-220	822-300	822-450				
Appearance:	Light amber, clear fluid						
Specific Gravity:							
@ 77°F. (25°C.)	0.9088	0.9107	0.9220				
122°F. (50°C.)	0.8925	0.8943	0.9050				
Moisture, wt. % max.:	0.1	0.1	0.1				
Pour Point (ASTM D97):	-15°F. (-26.1°C.)	-15°F. (-26.1°C.)	-15°F. (-26.1°C.)				
Viscosity:							
Temperature	822-220		822-300		822-450		
°F.	°C.	SUS	cSt	SUS	cSt	SUS	cSt
0	-17.8	5500	1202	9500	2063	24000	5213
32	0	1500	325	2400	520	4900	1062
77	25	380	82.0	510	110	780	168
100	37.8	220	47.3	300	64.6	450	97.0
122	50	140	29.6	180	38.5	270	58.1
167	75	77	14.8	92	18.5	120	25.0
210	98.9	55	8.8	60	10.2	70	13.0
Viscosity Index:	185	160	140				
ISO Grade:	46	68	100				
Total Acid Number, Max. (Neutralization No.):				10 mg. KOH/g			
Strong Acid No.:				0 mg. KOH/g			
Vapor Pressure:							
@ 68°F. (20.0°C.)				3.2 x 10 ⁻⁶ mm Hg.			
150 (65.6)				7.5 x 10 ⁻⁶			
Bulk Modulus:							
@ 68°F. (20°C.)							
3,000 psi:				266,900			
5,000 psi:				281,400			
10,000 psi:				316,200			
Thermal Conductivity:							
@ 66°F. (18.9°C.)				0.0971 BTU/hr.-ft. ² -°F./ft. (1.439 cal/hr. cm ² -°C./cm)			
@ 160°F. (7.1°C.)				0.0934 BTU/hr.-ft. ² -°F./ft. (1.385 cal/hr. cm ² -°C./cm)			
Specific Heat:							
@ 68°F. (20°C.)				0.49 BTU/lb.-°F (cal/°C. g)			
Coefficient of Thermal Expansion; per °F.:	4.06 x 10 ⁻⁴	4.08 x 10 ⁻⁴	4.17 x 10 ⁻⁴				
Solubility in Water:				Negligible			
Water Separation: (ASTM D-1401)				40:40:0 (30) ml. oil/water/emulsion (minutes)			
Foaming Tendency: (ASTM D-892)				pass			
Flash Point (C.O.C.):				500°F. (260°C.)			
Fire Point (C.O.C.):				550°F. (288°C.)			
Autoignition Temperature:				900°F. (482°C.)			
Pump Wear (ASTM 2882):				<20 mg. wt. loss, ring and vanes			

CONVERSION PROCEDURES

Phosphate ester base: QUINTOLUBRIC 822 fluids are miscible and compatible with phosphate esters which are in good condition (free of water and within recommended neutralization number (0.5)) and can be used as top-up. For a total conversion, the recommended procedure is to drain the old fluid (save for use in other systems) and recharge with QUINTOLUBRIC 822. Flushing is not required. Screens and filter elements should be cleaned or replaced. If seals and hoses are Viton/Teflon®, no changes are required. If butyl or EPR, a change to buna N is preferred, but not essential. These components can then be replaced in accordance with normal maintenance schedules. Quaker process engineers are available to assist in the conversion, test the quality of the phosphate ester and monitor the condition of QUINTOLUBRIC 822 following the conversion.

Water glycol/invert emulsion: QUINTOLUBRIC 822 fluids are not miscible or compatible with water containing fluids. Such fluids must be removed (up to 3% residual allowable) from the hydraulic system by draining and/or flushing. Quaker can supply a specially formulated compound which, when recirculated, emulsifies and traps residual water base fluid. Screens and filter elements should be cleaned or replaced. Seals and hoses normally used with water base fluids are generally compatible with QUINTOLUBRIC 822. The system is ready to be charged and operated with QUINTOLUBRIC 822. The fluid should be monitored carefully following the conversion for contamination; Quaker process engineers are trained to provide this service and keep you advised relative to fluid condition.

Oil base fluids: QUINTOLUBRIC 822 fluids are miscible and compatible with virtually all R & O and anti-wear mineral oil type fluids. To convert a system using a flammable hydraulic oil, simply drain and recharge with QUINTOLUBRIC 822. To insure adequate fire resistancy, at least 95% of the oil should be removed. Screens and filter elements should be cleaned and/or replaced.

3. COMPATIBLE

QUINTOLUBRIC 822 fluids are compatible with phosphate ester and oil base fluids and the inexpensive seals and hoses normally used with oil base fluids. QUINTOLUBRIC 822 offers excellent anti-wear properties in all industrial pumps.

SYSTEM COMPATIBILITY

Pumps and components: QUINTOLUBRIC 822 fluids can be used in virtually all industrial pumps. They offer the lubrication level of premium anti-wear oils and have been approved or endorsed by most pump manufacturers. Unlike the other higher density fire resistant fluids, components used with QUINTOLUBRIC 822 do not require derating; it may be used up to the design limits of the equipment.

Seals, hoses and packings: QUINTOLUBRIC 822 offers the unique capability of being compatible with elastomers normally used with oil base hydraulic fluids. A summary of elastomer compatability is shown on the next page.

ELASTOMER COMPATIBILITY SUMMARY

ELASTOMERS	RECOMMENDATION
Fluoro-elastomer (Viton, Teflon)	Satisfactory
Medium to high nitrile buna N	Satisfactory
Polyurethane	Satisfactory
Nylon	Satisfactory
Silicone Rubber	Satisfactory
Butyl	Satisfactory, but with reduced life expectancy*
EPR	Satisfactory, but with reduced life expectancy*
Neoprene	Satisfactory, but with reduced life expectancy*
Low nitrile buna N	Satisfactory, but with reduced life expectancy*

* Based on Laboratory Compatibility Studies

METALS

QUINTOLUBRIC 822 is compatible with iron and steel alloys and non-ferrous metals and their alloys. Lead containing bearing may exhibit surface pitting.

PAINTS AND COATINGS

QUINTOLUBRIC 822 is compatible with a large number of air cured and two component epoxy systems; however, because of the large number of types available and variations in their application, specific recommendations should be solicited from their manufacturer or the Quaker Hydraulic Laboratory. When possible, panel testing is recommended.

QUAKER SERVICE

Quaker chemical has served a variety of industries for over sixty years. Our staff of process engineers is available for timely and professional service; including hydraulic system surveys, conversion recommendations and assistance, and periodic system inspection to insure maximum operational efficiencies. An integral part of our QUINTOLUBRIC fluid service is periodic fluid sampling and analysis. Often, fluid condition variations forecast future system problems. The Quaker Hydraulic Research Laboratory provides direct customer assistance as required for system conversions and troubleshooting. Our primary goal is to provide you with the most cost effective hydraulic fluid and the support to insure it.

PACKAGING, SHIPPING AND STORAGE

QUINTOLUBRIC 822 fluids are shipped in 55 gallon, non-returnable, no deposit, oil drums. Drum bungs are provided with caps to minimize contamination and to identify prior use. QUINTOLUBRIC 822 is also provided in 340 gallon capacity Liqua-Bins; these are returnable containers which remain the property of Quaker Chemical and bear no service charges. Bulk shipments consistent with DOT regulations are possible.

QUINTOLUBRIC 822 fluids should be stored in protected locations, if possible, to prevent contamination and facilitate transfer. QUINTOLUBRIC 822 fluids offer little hazard in normal handling and require ordinary care.

RETURN LINE FILTER

Maintenance.

Frequency:

Use of an indicator gage allows maximum life from your Parker Spin-On Canister. When checked regularly, gage tells operator when to schedule maintenance of filter.

If a gage is not used, replace filter canister after first 100 hours of service, and every 500 hours thereafter. More frequent replacement may be required, depending on the amount of dirt entering the system and flow rate. If canisters are in service too long, system components may be damaged.

Methods:

When replacing a Spin-On Canister:

1. Turn off system; let pressure drop to zero.
2. Remove canister by hand or with a strap wrench.
3. Apply a film of system oil to outer gasket seal of new canister before installation.
4. Install new canister by twisting on hand tight.

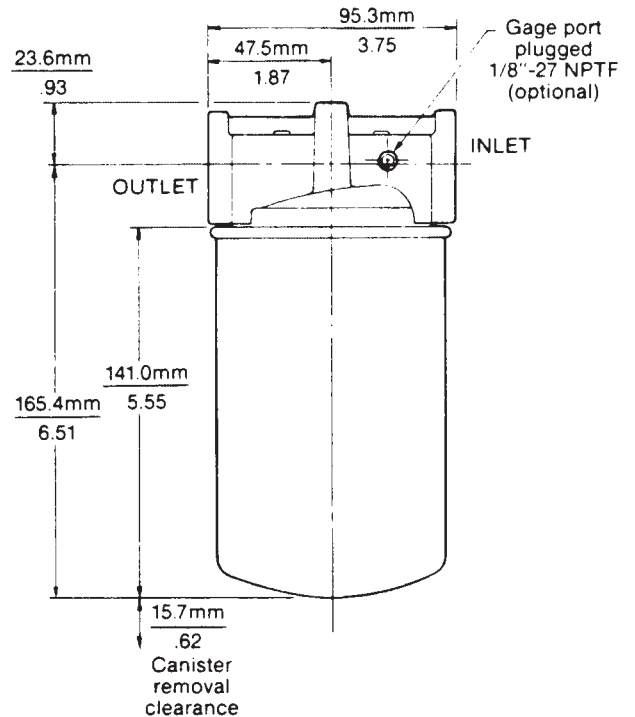

*Specifications.

Flow Capacity 76 lpm (20 GPM)
 Maximum Working Pressure 10 bar (150 psi)
 Operating Temperatures -40° C (-40° F) to
 +149° C (300° F)

Weights (approx.)

Complete Filter 1.02 kg (2.25 lbs.)
 Canister Only 0.50 kg (1.1 lb.)

Filtration Rating 10 Micron, Nominal
 (Beta (10) = 2.5)

Media Phenolic Impregnated
 Cellulose

Seals (Inner and Outer) Buna N, 70 DUR.

Gage (Optional) Detail A Compound Type,
 -30" Hg/0/60 psi

***Complete 12-AT Filter, or 12-AT Replacement
 Canister used on Parker Filter head.**

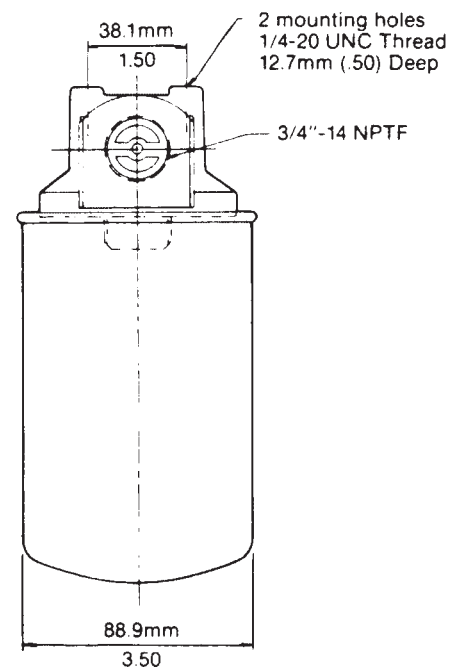

ALL DIMENSIONS ARE
 PLUS OR MINUS

$\frac{3.0\text{mm}}{.12}$

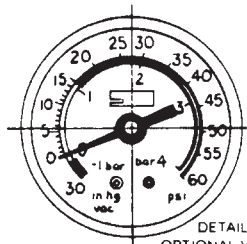

IN TANK PICK UP FILTER

TECHNICAL DATA:

SCREEN – The recently developed low cost screen is compatible with all known hydraulic oils in use today. The screen base is a nylon mesh welded at each cross-over section to maintain a uniform pore size. A silver coat is applied to the mesh to allow a coat of nickel to be applied, thus equalling the performance of a stainless steel.

MESH – The metal coat gives the nylon screen rigidity and is self-supporting.

NUT – Is produced from a high-strength, glass-filled nylon.

END CAP – Is aluminum, except when a bypass valve is included where the material is changed to steel for added strength.

BONDING – Continuous epoxy for compatibility with all fluids.

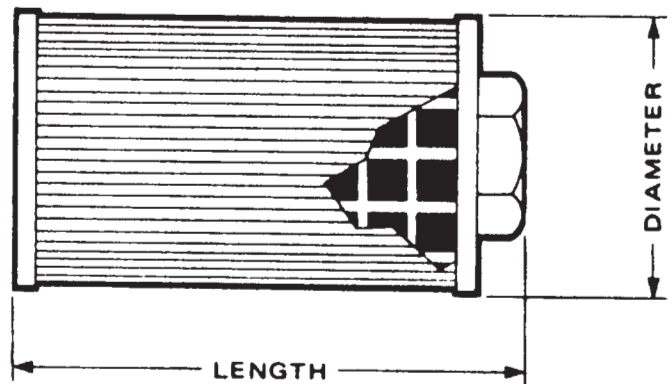

MODEL NUMBER DATA

CF	-	SE	-	5	-	3
Can Flo Identity		Suction Element Basic Series		GPM Rating 3 50 5 75 10 100 20 150 30		Bypass Omit if Not Required

FILTER MODEL (BASIC)	PORT SIZE A	FLOW RATE		SCREEN AREA		DIAMETER		LENGTH		WEIGHT	
		GPM	LPM	SQ. INS.	SQ. CMS.	INS.	MM	INS.	MM	LB	KG
CFSE-3	½" NPT	3	11.4	40	258	2.75	70	3.0	76	.25	0.11
CFSE-5	¾" NPT	5	19	60	387	2.75	70	5.0	127	.30	0.14
CFSE-10	1" NPT	10	38	125	806	2.75	70	6.5	165	.40	0.18
CFSE-20	1¼" NPT	20	76	160	1032	3.90	99	6.5	165	.50	0.23
CFSE-30	1½" NPT	30	114	300	1935	3.90	99	8.5	216	.65	0.30
CFSE-50	2" NPT	50	190	350	2258	3.90	99	10.0	254	.80	0.36
CFSE-75	2½" NPT	75	285	400	2581	5.35	136	12.48	317	1.00	0.45
CFSE-100	3" NPT	100	380	500	3226	5.35	136	13.0	330	1.25	0.57
CFSE-150	3" NPT	150	570	700	4516	5.35	136	15.0	381	1.50	0.68

Flow rates are based upon pressure drops across the element of less than 0.25 PSI (0.017 Bar.) with a fluid viscosity of 150 SSU (28 centistokes) clean element.

TROUBLE SHOOTING HYDRAULIC SYSTEM

PUMP MOTOR DOES NOT RUN:

1. Check the incoming power.
2. Check power through the motor overload.
3. Check the start-switches.
4. Check out motor and electrical connections.

MOTOR RUNS BUT NO PRESSURE ON HYDRAULIC GAUGE:

1. Check motor rotation. Looking at the pump from the return line oil filter end of the pump the rotation would be counter clockwise.
2. Check the oil level in the reservoir.
3. Check the valve pressure adjustment.
4. Check the pressure gauge, it may be defective.

MOTOR RUNS AND PRESSURE SHOWING ON OIL PRESSURE GAUGE BUT CYLINDERS WILL NOT MOVE:

1. Check flow control valves, they may have been shut off.
2. Inadequate pressure to pilot check valves.
3. Directional valve may not be operating properly. Watch the hoses to see if they move when the valve is operated.
4. Pressure too low, check gauge, should be 900 lbs.
5. Cylinders leaking by the pistons. Pressurize one side of the cylinder and **disconnect** the hose from the other side. Observe leakage, there should not be more than 2 cubic inches per minute.
6. Check oil pressure gauge, may not be working.

FURNACE IN UP POSITION AND WILL NOT COME DOWN:

1. Not enough pressure getting to pilot operated check valves. Valve or lines may be clogged or need cleaning.
2. Pilot operated check valves may be sticking.
3. Pilot operated check valves may need cleaning or replacing.

FURNACE UP AND SLOWLY GOES DOWN WHEN OPERATOR VALVE IS IN NEUTRAL POSITION:

1. Pilot operated check valve adjusting screw needs to be screwed in slightly.
2. Oil is leaking by the piston seals and they will have to be replaced.
3. In either of the above it will be one side of the furnace or the other and should **be obvious** as to which side is going down.

FURNACE SLOWLY TILTS WITHOUT OPERATING DIRECTIONAL CONTROL VALVE:

1. Check for leaks through the operating valve.

CYLINDER BODY SEAL LEAK:

1. Loose tie rods, tighten evenly
2. Excessive pressure, reduce to recommended pressure.
3. Seal deteriorated, gumming and soft, should be replaced. Check seal material compatibility with cylinder oil.

ROD AND SEAL LEAK:

1. Torn or worn seal. Examine the piston rod for dents, gauges or score marks. Replace the rod if the piston rod is rough.
2. Seal deterioration, soft or gummy. Replace seal and check seal compatibility with cylinder oil.
3. Check the rod gland bearing, if loose they may cause premature seal deterioration. Replace both the gland bearing and seal.
4. Seal deterioration, hard or loss of elasticity, usually due to heat exposure. Replace and shield from heat.

TROUBLE SHOOTING PUMPS

PUMP MAKES EXCESSIVE NOISE:

1. Check for leaks in the suction line
2. Check for leaks in the pump shaft seal.
3. Check the pump adaptor bolts holding the pump to the motor, they may be loose.
4. The relief or unloading valve may be set too high. Check the gauge to see if it is reading correct. The valve may have been set too high because of a faulty gauge.
5. Air in fluid lines. The oil level may be too low and are sucking in air at times.
6. Worn or sticking vanes, in vane type pump.
7. Worn or faulty bearing.
8. Reverse rotation on pump shaft.
9. Plugged or restricted suction line or suction strainer.
10. Plugged filter breather in the reservoir.
11. Loose or worn pump parts.
12. Suction filter too small.

PUMP FAILS TO DELIVER FLUID:

1. Low Fluid level in resevoir.
2. Oil intake strainer plugged.
3. Air leak in suction line preventing priming.
4. Pump shaft turning too slow. The universal joint may have come loose or defective.
5. The pump motor may be going bad or single phasing because of hlown fuse or broken wire.
6. Wrong shaft rotation.
7. The pump shaft broken or some other part in pump broken.
8. There may be dirt in the oil pump.

OIL LEAKAGE AROUND PUMP:

1. The shaft seal may be worn.
2. The pump housing bolts may be loose.
3. The hoses or pipes may be leaking around the pump.

EXCESSIVE PUMP WEAR:

1. Abrasive dirt in hydraulic oil being circulated through the system. Drain the oil and replace filters, in the intake and return lines.
2. System pressure is exceeding pump rating.
3. Check for pump mis-alignment or bolts loose.

PUMP PARTS INSIDE HOUSING BROKEN:

1. Seizure due to lack of oil.
2. Excessive pump pressure above pump rating.
3. Excessive torquing of housing bolts.
4. Solid matter being drawn in from reservoir and wedged in pump.
5. Oil temperature should not exceed 145°F.

DIRTY OIL:

1. Components not properly cleared after servicing.
2. Filter screen broken or missing.
3. Air breather cap left off.
4. Pipes not covered while servicing machine.
5. Filter elements not replaced at regular intervals. Should be replaced after first 100 hours and then every 500 hours.

T-200 HYDRAULIC TANK ASSEMBLY

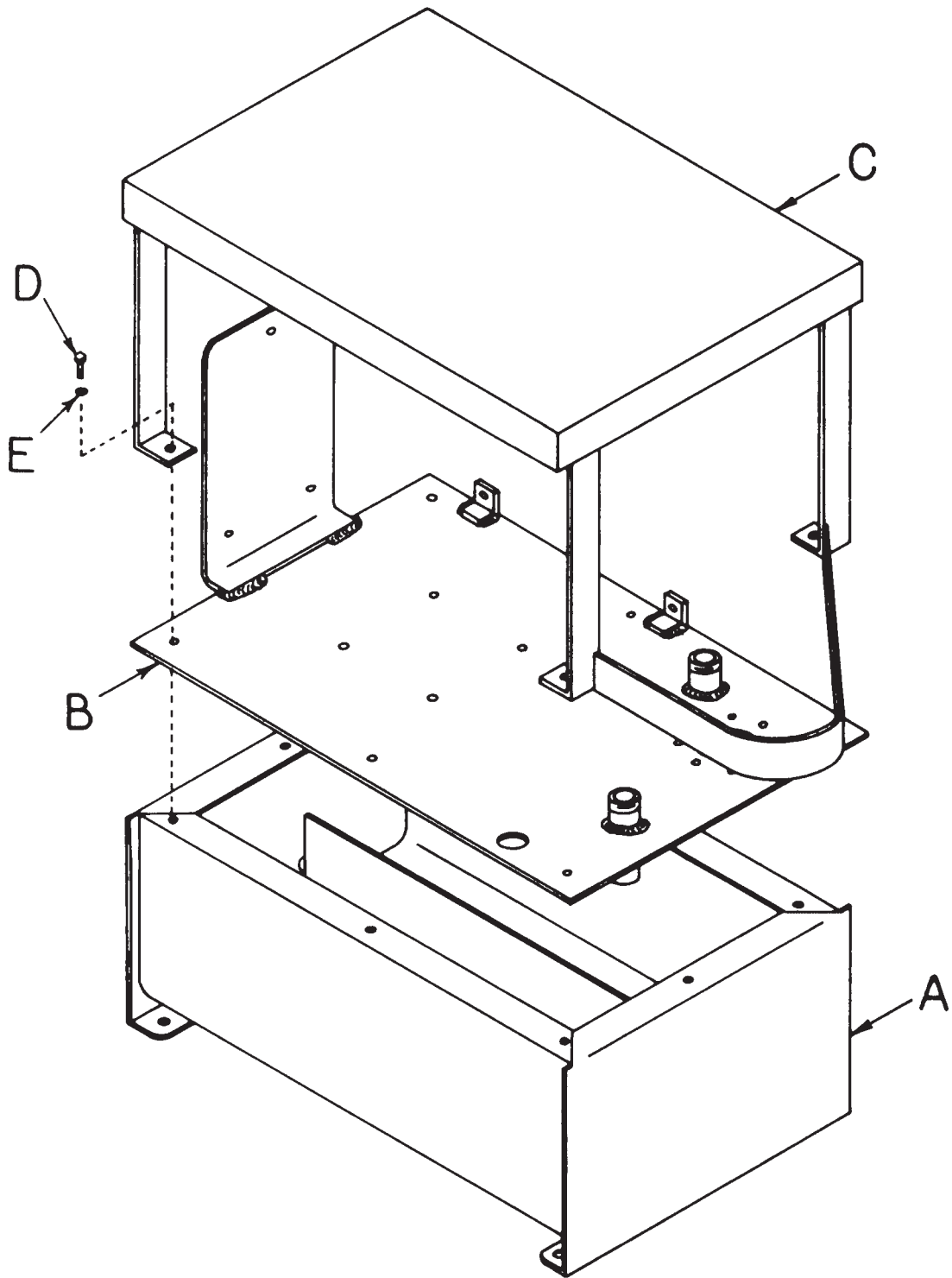

	OPN	DESCRIPTION	QTY
A	102690	Tank Assembly	1
B	102700	Tank Lid Assembly	1
C	102710	Tank Guard Assembly	1
D	000708	1/4" x 1" Hex Head Bolt	8
E	002112	1/4" Lock Washer	8